

Internal Gear Motor

Series QXM42-HS



- excellent suitability for high speeds
- low hydromechanical losses
- excellent cooling providing low operating temperatures, less stress to all moving parts and prevents premature aging of the hydraulic fluid.
- Cost-savings in system design, assembly and maintenance
- few moving parts and the hydrodynamic bearing effect ensure an exceptionally long life.
- Shaft accepts high radial loads
- very low noise level

1 Description

1.1 General

The QXM42-HS (High Speed) Internal Gear Motor was developed specifically for use at extremely high speeds.

Its high efficiency and extremely low noise levels also make a significant contribution to reducing the costs of both energy and anti-noise measures.

A double row angular ball bearing designed for high external loads and an integrated anti-cavitation valve guarantee a long life.

The integrated check valve prevents cavitation during unbraked spin out from maximal speed.

Thanks to the special motor flange, adapted for such applications, and the integral ports for auxiliary functions, the motor can be used in many applications without needing any further modification.

1.2 Application examples

- Saw-drive motor in forestry harvesters
- Fan drives in mobile machines

2 Symbols

2.1 QXM42-...R-HS-.SKRG1..

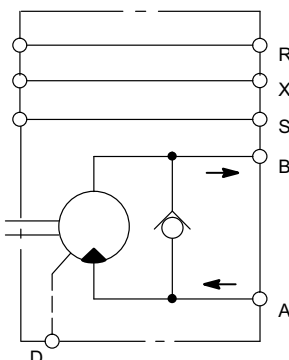

2.2 QXM42-...L-HS-.SKRG1..

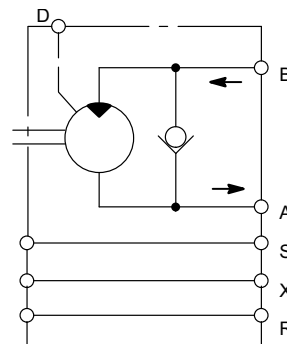

Reference: 100-P-000092-US-03

3 Technical data

3.1 General

Characteristics	Description, value, unit
Installation attitude	unrestricted
Mounting method	4-hole set back motor flange
Direction of rotation	right or left (clockwise or counter clockwise)
Motor drive method	chain pinion direct on the motor shaft or coupling
Ports	A/B = working lines, D = external drain line, R/S/X = ports for auxiliary functions
Fluids	HLP-mineral oil DIN 51524 part 2; HEES synthetic ester
Minimum fluid cleanliness	NAS 1638, class 9 or ISO 4406, code 20/18/15
Viscosity category	VG32, VG46, VG68
Viscosity range	70 - 300 S.U.S. (15 - 60 mm ² /s) for saw operation 4700 S.U.S. (1000 mm ² /s) for cold at max. 5000 rpm and 1450 PSI (100 bar) max. pressure
Fluid temperature range	min. 14 °F / max. 176 °F (start temperature -22 °F) min. 10 °C / max. 80 °C (start temperature -30 °C)
Total restriction	port A + port B < continuous-/ intermediate pressure
Max. pressure in drain line	(see sect. 4.3)
Motor weight	32 lbs (14.5 kgs)

3.2 Displacement

The operating data are valid for mineral oils with a viscosity of 200 S.U.S. (42 mm²/s)

Type	Displacement effective in ³ /rev (cm ³ /rev)	Motor speed in rpm		Continuous pressure PSI (bar)	Maximum intermediate pressure PSI (bar) max. 2 s
		Maximum speed max. 2 s	Minimum speed ¹⁾		
QXM42-020.-HS-	1.24 (20,3)	10500	100	3500 (240)	4000 (280)
QXM42-025.-HS-	1.53 (25,1)	9500	100	3500 (240)	4000 (280)
QXM42-032.-HS-	1.97 (32,3)	8500	100	3500 (240)	4000 (280)

Type	Output torque ²⁾ ib-in (Nm)	Maximum output power HP (kW) max. 2 s	Moment of inertia [10 ⁻³ kgm ²]
QXM42-020.-HS-	510 (58)	87 (65)	0,93
QXM42-025.-HS-	620 (70)	87 (65)	1,15
QXM42-032.-HS-	780 (88)	87 (65)	1,48

1) for intermittent operation only (continuous speed please ask Bucher Hydraulics)

2) at Δp= 2900 PSI (200 bar) / n= 5000 min⁻¹

3.2.1 External loads

The QXM42-HS features a rugged integrated double-row ball bearing. Unlike the hydrodynamic bearings of the motor the ball bearing is subject to continuous wear. The lifetime of this bearing is determined by the following factors:

- Magnitude of external shaft load (radial load)
- Direction of external shaft load (axial load push or pull)
- Motor speed
- Viscosity of the fluid
- Degree of contamination of the fluid

Depending on the use of the QXM42-HS certain loads and working cycles occur. In order to establish the relevant bearing life it is necessary to know the load profile and the operating conditions of the motor. Please ask Bucher Hydraulics for your specific application.

4 Performance graphs

Values are valid for mineral oil HLP 46 at an oil temperature (reservoir) of 110°F (43°C)

4.1 Starting torques M

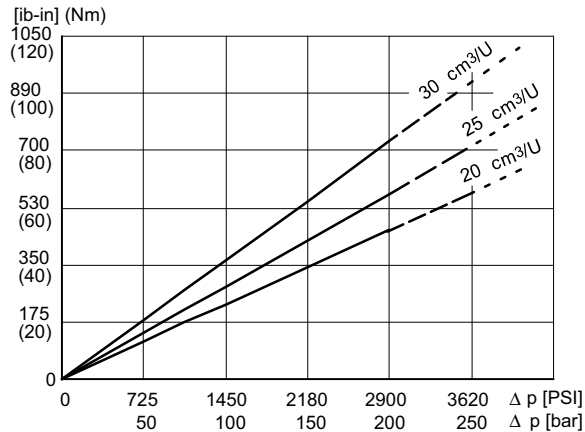

4.3 Maximum shaft seal pressure

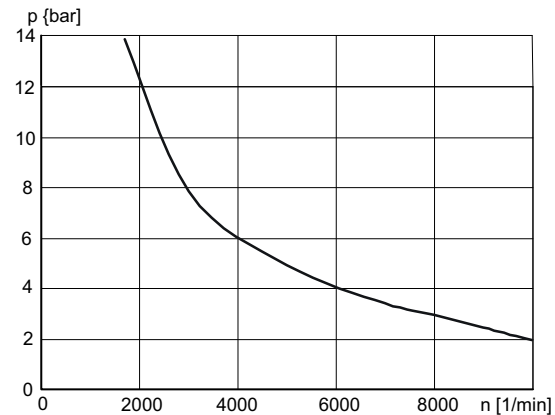

4.2 Oil temperatures at drain port

Measured with QXM42-020.-HS-...

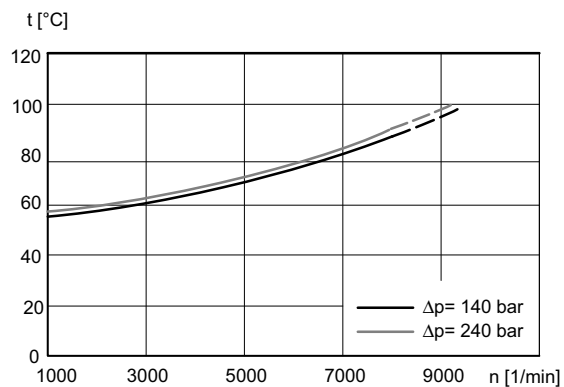

4.4 Volumetric efficiency

4.4.1 Type QXM42-020.-HS-...

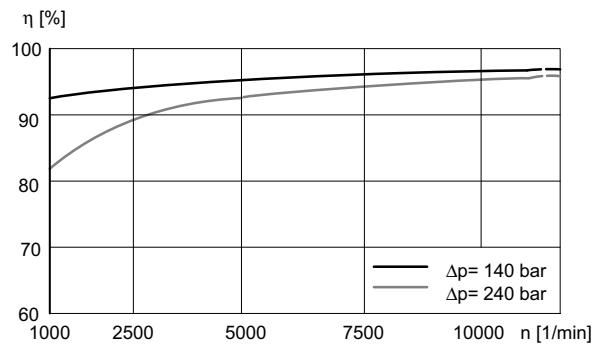

4.4.2 Type QXM42-025.-HS-...

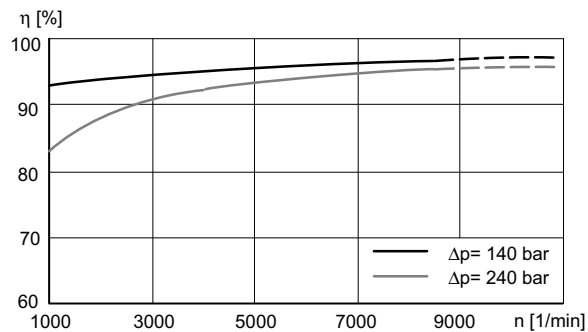

4.4.3 Type QXM42-032.-HS-...

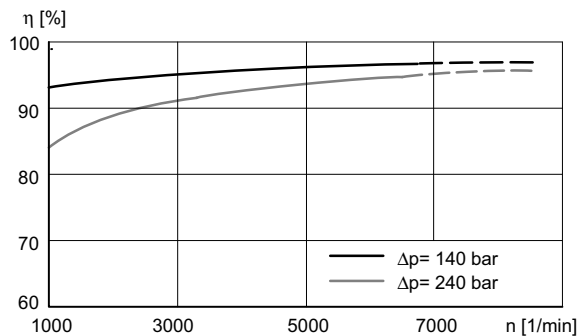

4.5 Hydromechanical efficiency

4.5.1 Type QXM42-020.-HS-...

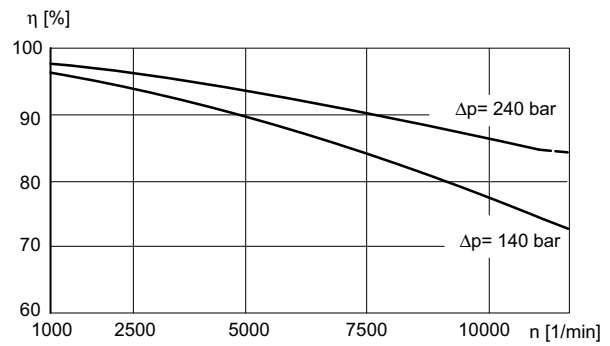

4.5.2 Type QXM42-025.-HS-...

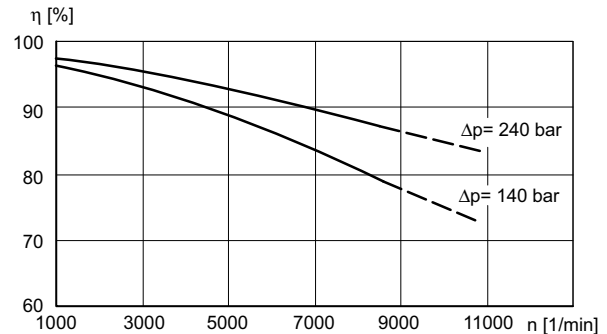

4.5.3 Type QXM42-032.-HS-...

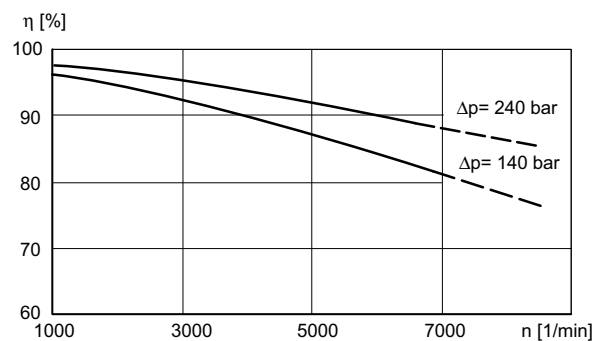

5 Dimensions

5.1 QXM42-...R-HS-SKRG1..

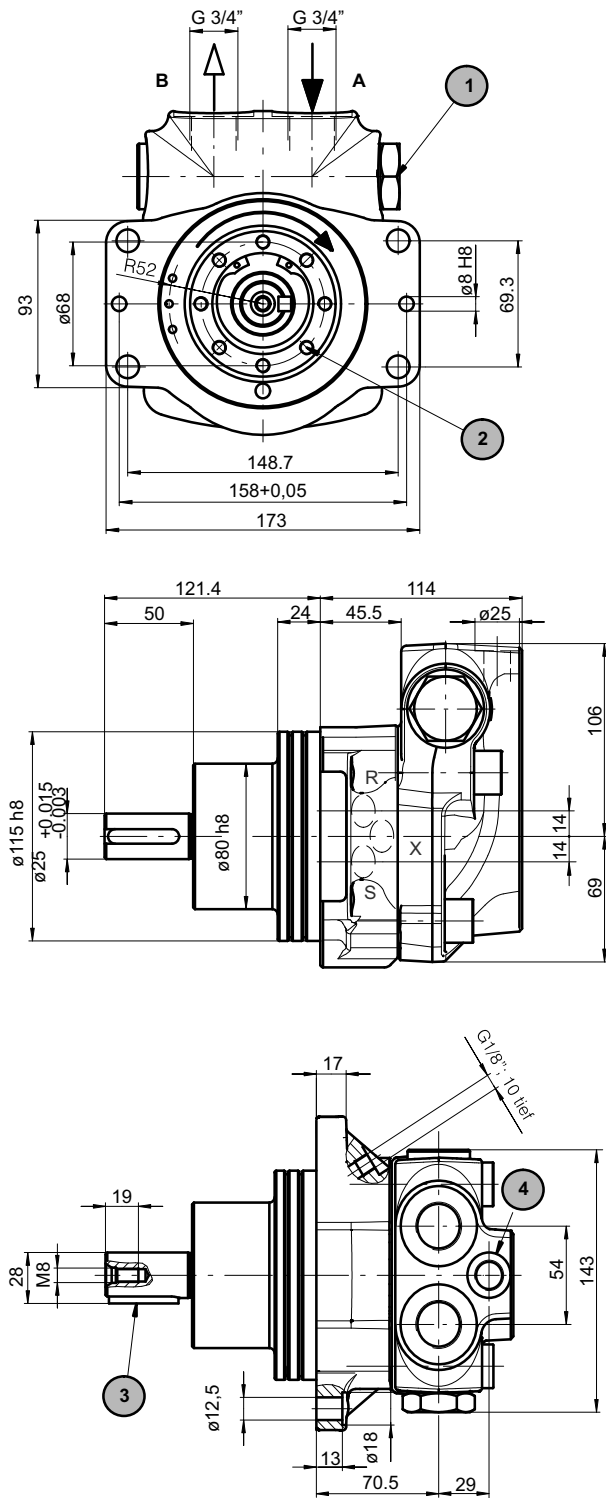

1	Anti cavitation valve
2	8 x M8; depth 12
3	DIN 6885 A8 x 7 x 40

5.2 QXM42-...L-HS-SKRG1..

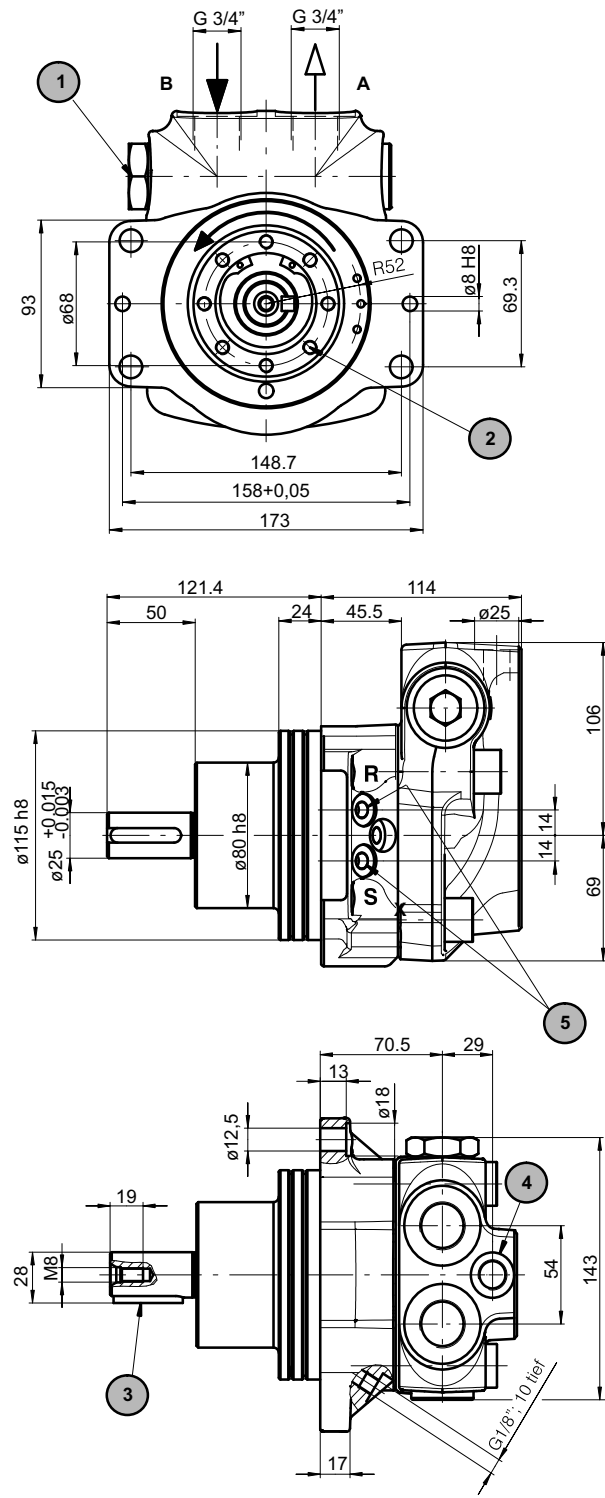

4	Drain port G3/8"
5	Port R, S and X: G1/8"; depth 8 (X = without identification)

6 Ordering code

	Q	X	M	4	2	-	0	2	0	R	-	H	S	-	N	S	K	R	G	1	P	A	/			
Series Internal Gear Motor																										
Frame size 4																										
Pressure range 2																										
Displacement in cm ³ /U							020 / 025 / 032																			
Direction of rotation							cw (right) = R ccw (left) = L																			
Version							High speed = HS																			
Sealing material							NBR = N FKM = F																			
Mounting flange							Setback = S																			
Shaft							Metric key shaft Ø25 = K																			
Main ports							A + B 3/4" = R																			
Additional ports							R, S + X 1/8" = G																			
Anti cavitation valve							one = 1																			
Modifications							no = O black primer = P																			
Design code							= A (inserted by the factory)																			
Options							(inserted by the factory)																			

7 Operation instructions

7.1 Temperature and viscosity

The temperature should not exceed 70 °C in the main circuit.

At operating temperature, the viscosity of the hydraulic fluid should be above 15 mm²/s. At start-up, the viscosity should not exceed 1000 mm²/s.

Up to the operating viscosity the motor must not be loaded.

7.2 Cold start

The majority of hydraulic motor breakdowns are caused during the first minutes of a cold start. The lifetime of a hydraulic motor may be drastically reduced when during the cold start phase the shaft speed exceeds 5,000 rpm and the pressure at the motor is in excess of 100 bar.

 **TIP:** For runing the system up (cold start) use a log with a dia. of < 15cm to make min. 20 short cuts each < 1 sec. and after each cut pause the procedure for min. 2 secs.

info.kl@bucherhydraulics.com

www.bucherhydraulics.com

© 2009 by Bucher Hydraulics GmbH, D-79771 Klettgau

All rights reserved.

Data is provided for the purpose of product description only, and must not be construed as warranted characteristics in the legal sense. The information does not relieve users from the duty of conducting their own evaluations and tests. Because the products are subject to continual improvement, we reserve the right to amend the product specifications contained in this catalogue.

Classification: 420.245.000.200